

**Dimensions**

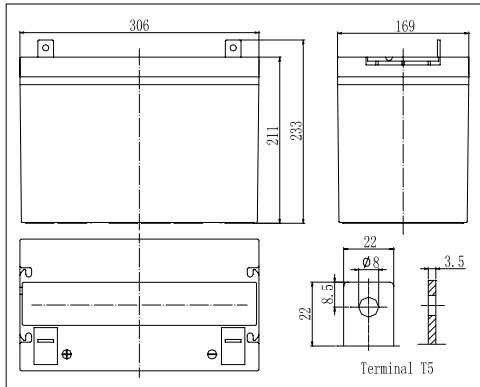

**Specifications**

Nominal Voltage		12 V
Capacity(10HR, 25°C)		90Ah
Dimension	Length	306mm (12.1inch)
	Width	169mm (6.65inch)
	Height	211mm (8.31inch)
	Total Height	233mm (9.17inch)
Approx. Weight		29kg (64.0lbs)
Internal resistance (Fully charged, 25°C)		Approx.5.2m Ω
Capacity affected by temperature (10HR)	40°C	102%
	25°C	100%
	0°C	85%
	-15°C	65%
Self-discharge (25°C)	3 month	Remaining Capacity: 91%
	6 month	Remaining Capacity: 82%
	12 month	Remaining Capacity: 65%
Nominal operating temperature		25°C ± 3°C (77°F ± 5°F)
Operating temperature range		-15°C ~ 70°C (5°F ~ 158°F)
Float charging voltage(25°C)		13.50 to 13.80V
Cyclic charging voltage(25°C)		14.50 to 14.90V
Maximum charging current		27A
Terminal material		Copper
Maximum discharge current		900A(5 sec.)

- ◆ Absorbent glass mat technology;
- ◆ Recognized by UL & CE;
- ◆ ABS container.

**The Relationship for Open Circuit Voltage and Residual Capacity (25°C)**

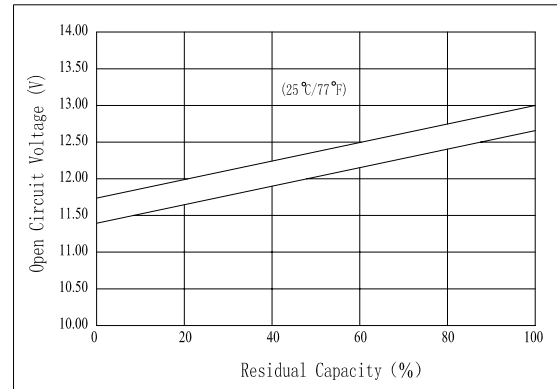

**Charging Characteristics(25°C)**

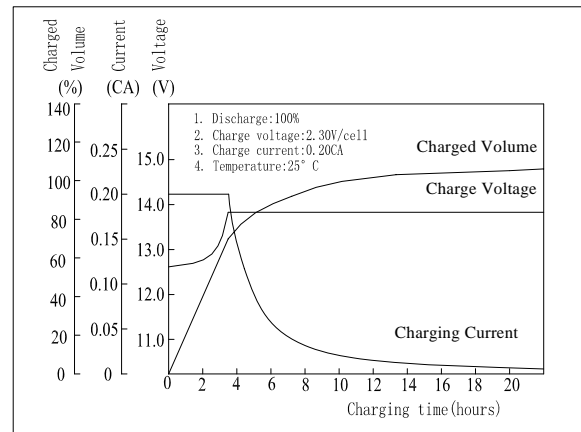

**Cycle Life(25°C)**

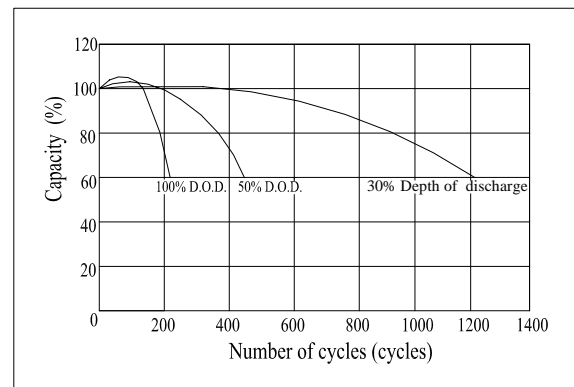

Note: Floating life at 20°C designed for 7 to 10 years.

**Constant Current Discharge Characteristics (A, 25°C)**

F.V/TIME	5min	10min	15min	30min	60min	3h	5h	10h	20h
9.60V	275	183	146	91.7	56.7	23.3	16.4	9.14	4.80
10.2V	261	174	140	88.1	54.4	23.0	16.2	9.05	4.75
10.8V	246	164	133	83.7	51.7	22.5	15.9	9.00	4.73

**Constant Power Discharge Characteristics (Watt, 25°C)**

F.V/TIME	5min	10min	15min	30min	60min	3h	5h	10h	20h
9.60V	2887	1980	1598	1029	646	274	194	109	57.6
10.2V	2743	1881	1534	988	621	270	191	108	57.0
10.8V	2578	1768	1457	939	589	264	188	108	56.7