

Dimensions

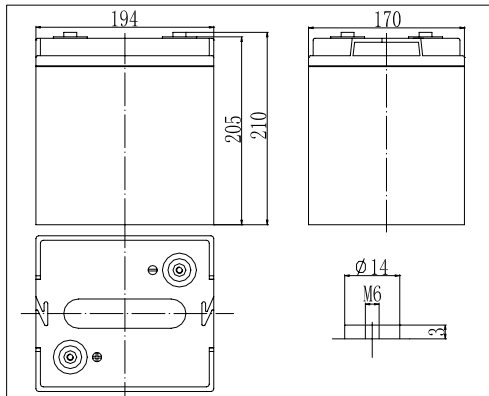

Specifications

Nominal Voltage		6 V
Capacity(10HR, 25°C)		100 Ah
Dimension	Length	194mm (7.64inch)
	Width	170mm (6.69inch)
	Height	205mm (8.07inch)
	Total Height	210mm (8.27inch)
Approx. Weight		16.5kg (36.4lbs)
Internal resistance (Fully charged, 25°C)		Approx. 3.5m Ω
Capacity affected by temperature (10HR)	40°C	102%
	25°C	100%
	0°C	85%
	-15°C	65%
Self-discharge (25°C)	3 month	Remaining Capacity: 91%
	6 month	Remaining Capacity: 82%
	12 month	Remaining Capacity: 65%
Nominal operating temperature		25°C ± 3°C (77°F ± 5°F)
Operating temperature range		-15°C ~ 50°C (5°F ~ 122°F)
Float charging voltage(25°C)		6.75 to 6.90V
Cyclic charging voltage(25°C)		7.25 to 7.45V
Maximum charging current		30A
Terminal material		Copper
Maximum discharge current		800A(5 sec.)

- ◆ Absorbent glass mat technology;
- ◆ Recognized by UL & CE;
- ◆ ABS container.

Charging Characteristics(25°C)

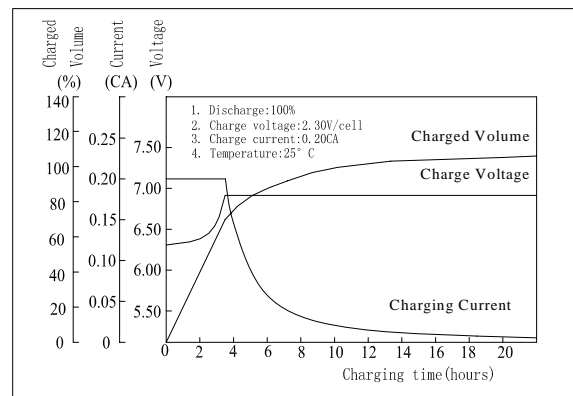

Cycle Life(25°C)

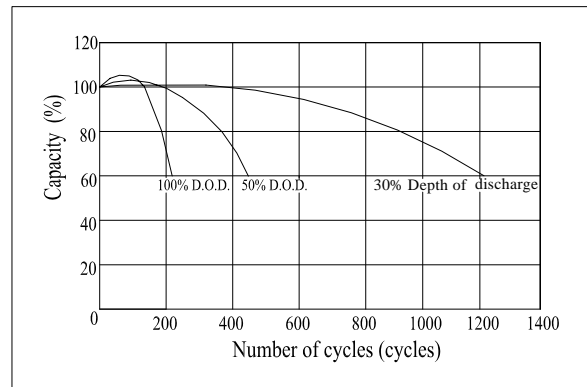

Note: Floating life at 20°C designed for 7 to 10 years.

Constant Current Discharge Characteristics (A, 25°C)

F.V/TIME	5min	10min	15min	30min	60min	3h	5h	10h	20h
4.80V	320	220	175	108	65.0	26.4	18.5	10.3	5.35
5.10V	304	209	168	104	62.4	26.0	18.2	10.2	5.35
5.40V	286	196	160	98.8	59.3	25.5	17.8	10.0	5.30

Constant Power Discharge Characteristics (Watt, 25°C)

F.V/TIME	5min	10min	15min	30min	60min	3h	5h	10h	20h
4.80V	1680	1188	961	606	370	155	109	62.0	32.1
5.10V	1596	1129	923	584	355	153	107	61.0	32.1
5.40V	1502	1059	879	555	338	150	105	60.0	31.8