

Dimensions

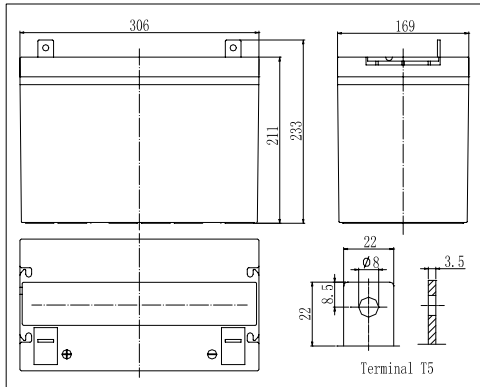

Specifications

Nominal Voltage		12 V
Capacity(10HR, 25°C)		95Ah
Dimension	Length	306mm (12.1inch)
	Width	169mm (6.65inch)
	Height	211mm (8.31inch)
	Total Height	233mm (9.17inch)
Approx. Weight		29kg (64.0lbs)
Internal resistance (Fully charged, 25°C)		Approx.5mΩ
Capacity affected by temperature (10HR)	40°C	102%
	25°C	100%
	0°C	85%
	-15°C	65%
Self-discharge (25°C)	3 month	Remaining Capacity: 91%
	6 month	Remaining Capacity: 82%
	12 month	Remaining Capacity: 65%
Nominal operating temperature		25°C ± 3°C (77°F ± 5°F)
Operating temperature range		-15°C ~ 50°C (5°F ~ 122°F)
Float charging voltage(25°C)		13.50 to 13.80V
Cyclic charging voltage(25°C)		14.50 to 14.90V
Maximum charging current		28.5A
Terminal material		Copper
Maximum discharge current		950A(5 sec.)

- ◆ Absorbent glass mat technology;
- ◆ Recognized by UL & CE;
- ◆ ABS container.

The Relationship for Open Circuit Voltage and Residual Capacity (25°C)

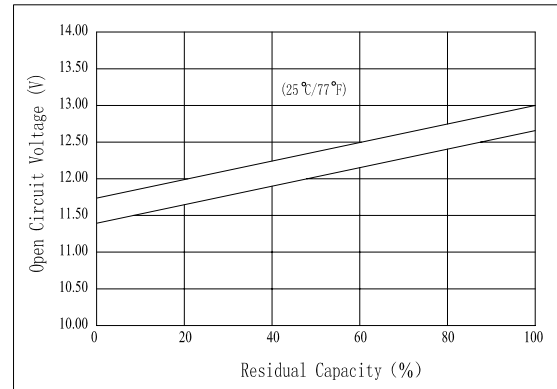

Charging Characteristics(25°C)

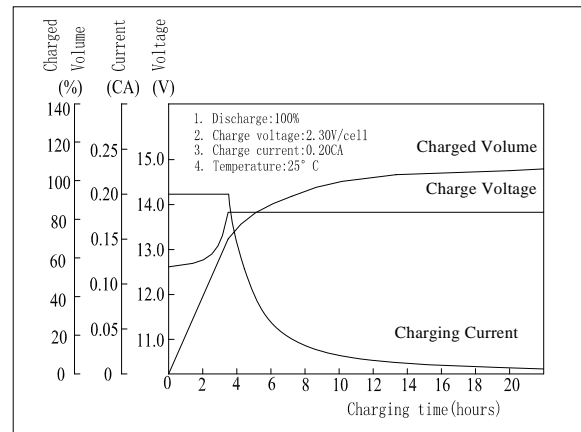

Cycle Life(25°C)

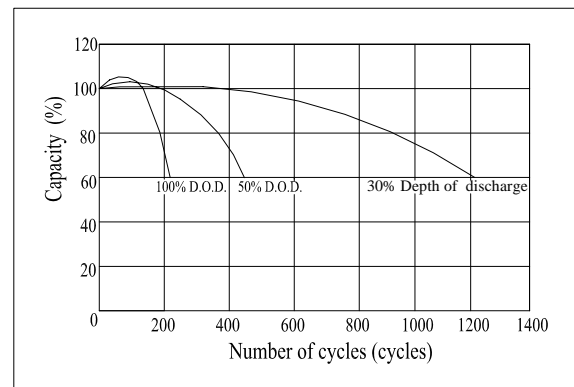

Note: Floating life at 20°C designed for 7 to 10 years.

Constant Current Discharge Characteristics (A, 25°C)

F.V/TIME	5min	10min	15min	30min	60min	3h	5h	10h	20h
9.60V	299	200	157	98.8	59.9	24.6	17.4	9.64	5.06
10.2V	284	190	150	94.8	57.5	24.2	17.1	9.56	5.02
10.8V	267	178	143	90.1	54.6	23.7	16.8	9.50	4.99

Constant Power Discharge Characteristics (Watt, 25°C)

F.V/TIME	5min	10min	15min	30min	60min	3h	5h	10h	20h
9.60V	3142	2155	1721	1109	682	289	205	115	60.7
10.2V	2985	2047	1652	1064	655	285	202	114	60.2
10.8V	2806	1924	1570	1011	622	279	198	114	59.9