

**Dimensions**

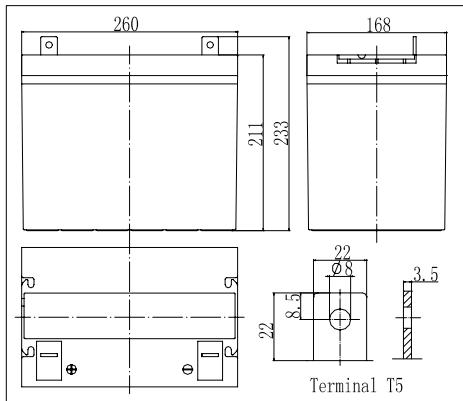

**Specifications**

Nominal Voltage	12 V	
Capacity(10HR, 25°C)	60Ah	
Dimension	Length	260mm (10.24inch)
	Width	168mm (6.61inch)
	Height	211mm (8.31inch)
	Total Height	233mm (9.17inch)
Approx. Weight	20.5kg (45.2lbs)	
Internal resistance (Fully charged, 25°C)	Approx. 5.7mΩ	
Capacity affected by temperature (10HR)	40°C	102%
	25°C	100%
	0°C	85%
	-15°C	65%
Self-discharge (25°C)	3 month	Remaining Capacity: 91%
	6 month	Remaining Capacity: 82%
	12 month	Remaining Capacity: 65%
Nominal operating temperature	25°C ± 3°C (77°F ± 5°F)	
Operating temperature range	-15°C ~ 50°C (5°F ~ 122°F)	
Float charging voltage(25°C)	13.50 to 13.80V	
Cyclic charging voltage(25°C)	14.50 to 14.90V	
Maximum charging current	18A	
Terminal material	Copper	
Maximum discharge current	600A(5 sec.)	

- ◆ Absorbent glass mat technology;
- ◆ Recognized by UL & CE;
- ◆ ABS container.

**Charging Characteristics(25°C)**

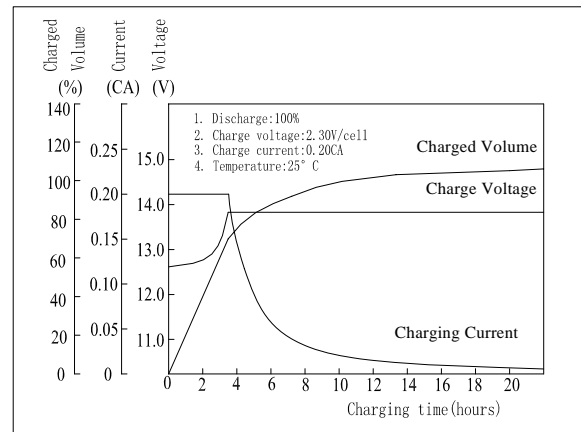

**Cycle Life(25°C)**

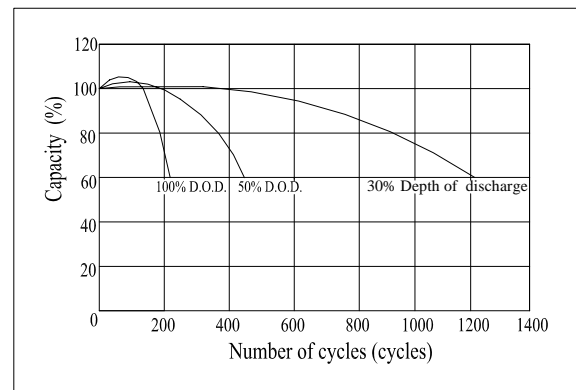

Note: Floating life at 20°C designed for 7 to 10 years.

**Constant Current Discharge Characteristics (A, 25°C)**

F.V/TIME	5min	10min	15min	30min	60min	3h	5h	10h	20h
9.60V	189	126	99.0	62.4	37.8	15.5	11.0	6.09	3.20
10.2V	180	120	95.0	59.9	36.3	15.3	10.8	6.04	3.17
10.8V	169	113	90.3	56.9	34.5	15.0	10.6	6.00	3.15

**Constant Power Discharge Characteristics (Watt, 25°C)**

F.V/TIME	5min	10min	15min	30min	60min	3h	5h	10h	20h
9.60V	1985	1361	1087	700	431	183	130	72.7	38.4
10.2V	1885	1293	1044	672	414	180	128	72.1	38.0
10.8V	1772	1215	991	639	393	176	125	72.1	37.8