

Dimensions

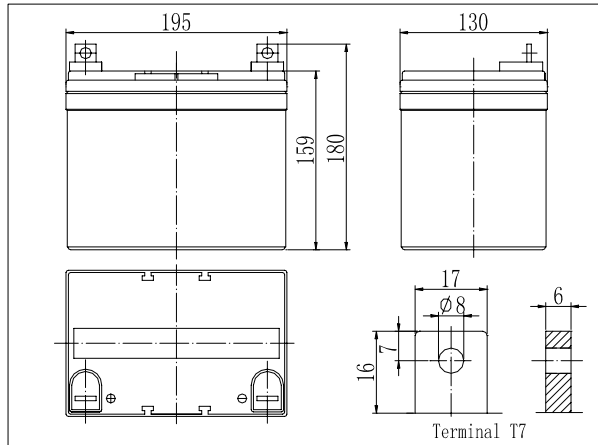

Specifications

Nominal Voltage	12 V	
Capacity(10HR, 25°C)	35 Ah	
Dimension	Length	195mm (7.68inch)
	Width	130mm (5.12inch)
	Height	159mm (6.26inch)
	Total Height	180mm (7.09inch)
Approx. Weight	11.3kg (24.9lbs)	
Internal resistance (Fully charged, 25°C)	Approx. 9.7mΩ	
Capacity affected by temperature (10HR)	40°C	102%
	25°C	100%
	0°C	85%
	-15°C	65%
Self-discharge (25°C)	3 month	Remaining Capacity: 91%
	6 month	Remaining Capacity: 82%
	12 month	Remaining Capacity: 65%
Nominal operating temperature	25°C ± 3°C (77°F ± 5°F)	
Operating temperature range	-15°C ~ 50°C (5°F ~ 122°F)	
Float charging voltage(25°C)	13.50 to 13.80V	
Cyclic charging voltage(25°C)	14.50 to 14.90V	
Maximum charging current	10.5A	
Terminal material	Lead	
Maximum discharge current	350A(5 sec.)	

- ◆ Absorbent glass mat technology;
- ◆ Recognized by UL & CE;
- ◆ ABS container.

Charging Characteristics(25°C)

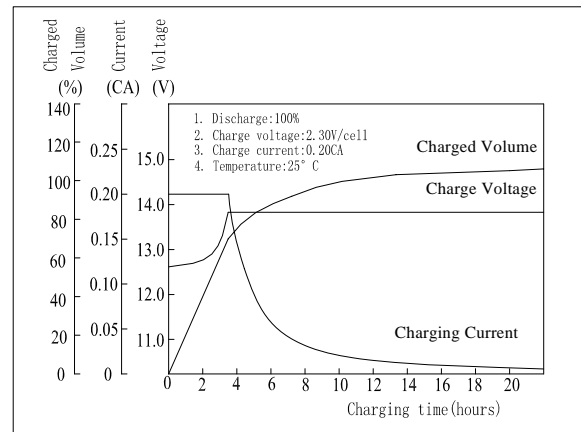

Cycle Life(25°C)

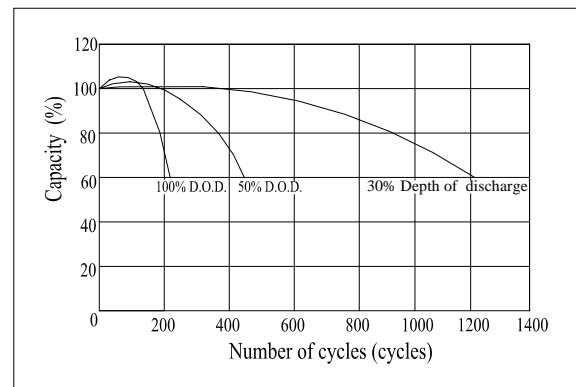

Note: Floating life at 20°C designed for 7 to 10 years.

Constant Current Discharge Characteristics (A, 25°C)

F.V/TIME	5min	10min	15min	30min	60min	3h	5h	10h	20h
9.60V	116	74.0	61.0	36.0	22.0	8.93	6.39	3.55	1.80
10.2V	110	70.3	58.6	34.7	21.1	8.80	6.30	3.52	1.78
10.8V	104	66.1	55.6	32.8	20.1	8.62	6.17	3.50	1.77

Constant Power Discharge Characteristics (Watt, 25°C)

F.V/TIME	5min	10min	15min	30min	60min	3h	5h	10h	20h
9.60V	1218	799	670	404	251	105	75.5	42.4	21.6
10.2V	1157	759	643	388	241	103	74.5	42.0	21.4
10.8V	1088	714	611	368	229	101	72.9	42.0	21.2