

Dimensions

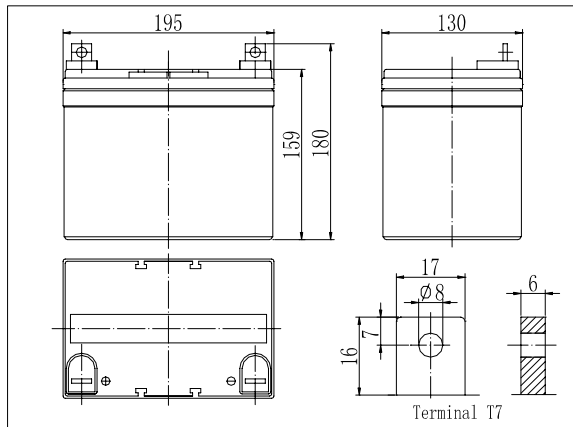

Specifications

Nominal Voltage	12 V	
Capacity(10HR, 25°C)	33 Ah	
Dimension	Length	195mm (7.68inch)
	Width	130mm (5.12inch)
	Height	159mm (6.26inch)
	Total Height	180mm (7.09inch)
Approx. Weight	10.2kg (22.5lbs)	
Internal resistance (Fully charged, 25°C)	Approx. 10m Ω	
Capacity affected by temperature (10HR)	40°C	102%
	25°C	100%
	0°C	85%
	-15°C	65%
Self-discharge (25°C)	3 month	Remaining Capacity: 91%
	6 month	Remaining Capacity: 82%
	12 month	Remaining Capacity: 65%
Nominal operating temperature	25°C ± 3°C (77°F ± 5°F)	
Operating temperature range	-15°C ~ 50°C (5°F ~ 122°F)	
Float charging voltage(25°C)	13.50 to 13.80V	
Cyclic charging voltage(25°C)	14.50 to 14.90V	
Maximum charging current	9.9A	
Terminal material	Lead	
Maximum discharge current	330A(5 sec.)	

- ◆ Absorbent glass mat technology;
- ◆ Recognized by UL & CE;
- ◆ ABS container.

Charging Characteristics(25°C)

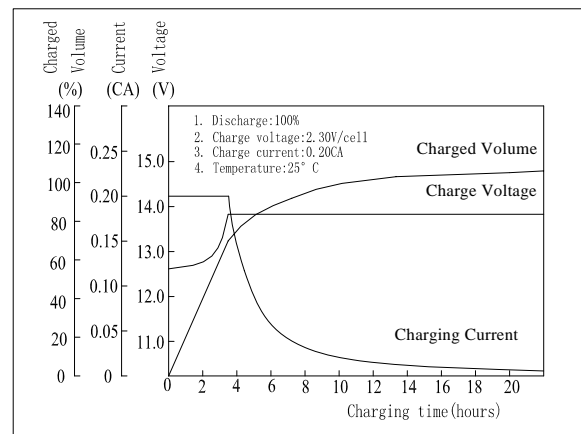

Cycle Life(25°C)

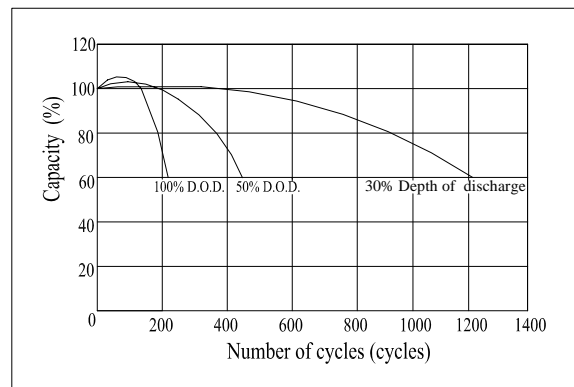

Note: Floating life at 20°C designed for 7 to 10 years.

Constant Current Discharge Characteristics (A, 25°C)

F.V/TIME	5min	10min	15min	30min	60min	3h	5h	10h	20h
9.60V	110	70.5	58.0	34.0	20.8	8.85	6.07	3.35	1.74
10.2V	105	67.0	55.6	32.6	20.0	8.60	5.95	3.33	1.72
10.8V	98.6	63.0	52.8	31.0	19.0	8.25	5.77	3.30	1.68

Constant Power Discharge Characteristics (Watt, 25°C)

F.V/TIME	5min	10min	15min	30min	60min	3h	5h	10h	20h
9.60V	1155	762	637	381	237	104	71.7	40.0	20.9
10.2V	1101	724	611	365	228	101	70.3	39.8	20.6
10.8V	1035	680	580	348	205	97	68.2	39.4	20.2