

Dimensions

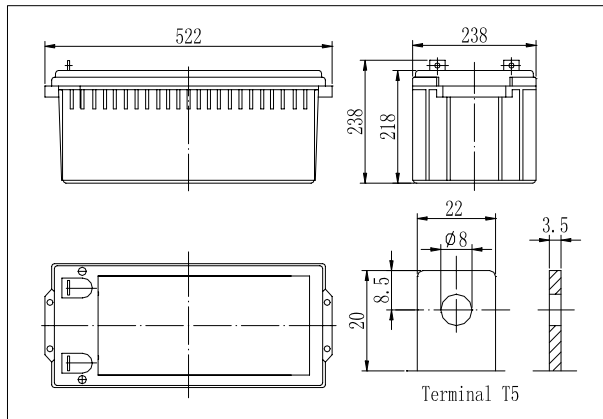

Specifications

Nominal Voltage	12 V	
Capacity(10HR, 25°C)	200 Ah	
Dimension	Length	522mm (20.55inch)
	Width	238mm (9.37inch)
	Height	218mm (8.58inch)
	Total Height	238mm (9.37inch)
Approx. Weight	65kg (143.3lbs)	
Internal resistance (Fully charged, 25°C)	Approx. 3m Ω	
Capacity affected by temperature (10HR)	40°C	102%
	25°C	100%
	0°C	85%
	-15°C	65%
Self-discharge (25°C)	3 month	Remaining Capacity: 91%
	6 month	Remaining Capacity: 82%
	12 month	Remaining Capacity: 65%
Nominal operating temperature	25°C ± 3°C (77°F ± 5°F)	
Operating temperature range	-15°C ~ 50°C (5°F ~ 122°F)	
Float charging voltage(25°C)	13.50 to 13.80V	
Cyclic charging voltage(25°C)	14.50 to 14.90V	
Maximum charging current	60A	
Terminal material	Copper	
Maximum discharge current	1600A(5 sec.)	

- ◆ Absorbent glass mat technology;
- ◆ Recognized by UL & CE;
- ◆ ABS container.

Charging Characteristics(25°C)

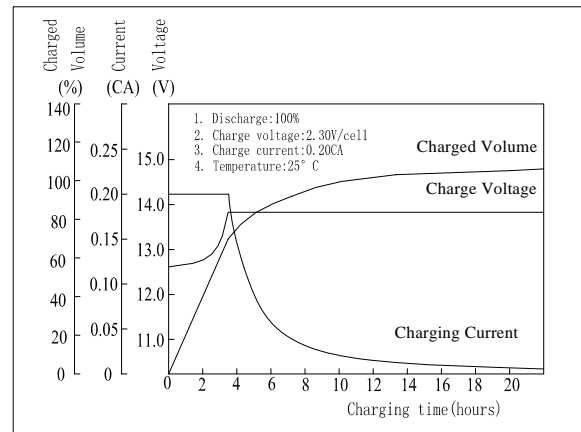

Cycle Life(25°C)

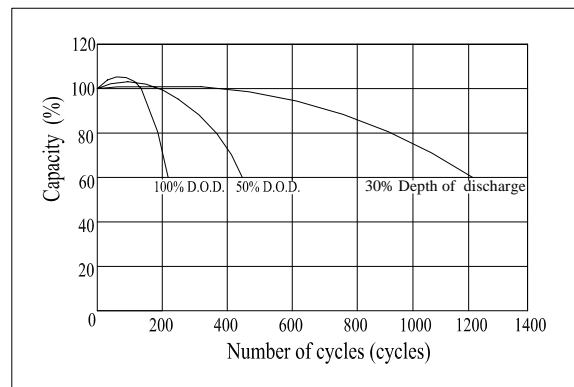

Note: Floating life at 20°C designed for 7 to 10 years.

Constant Current Discharge Characteristics (A, 25°C)

F.V/TIME	5min	10min	15min	30min	60min	3h	5h	10h	20h
9.60V	650	430	370	210	130	130	55.0	38.2	10.4
10.2V	618	409	355	202	125	53.5	53.5	37.0	10.3
10.8V	580	384	337	192	119	52.4	52.4	36.3	10.2

Constant Power Discharge Characteristics (Watt, 25°C)

F.V/TIME	5min	10min	15min	30min	60min	3h	5h	10h	20h
9.60V	6825	4644	4063	2356	1482	639	444	242	124
10.2V	6484	4421	3900	2262	1425	629	437	240	123
10.8V	6095	4147	3705	2149	1352	617	429	240	122