

Dimensions

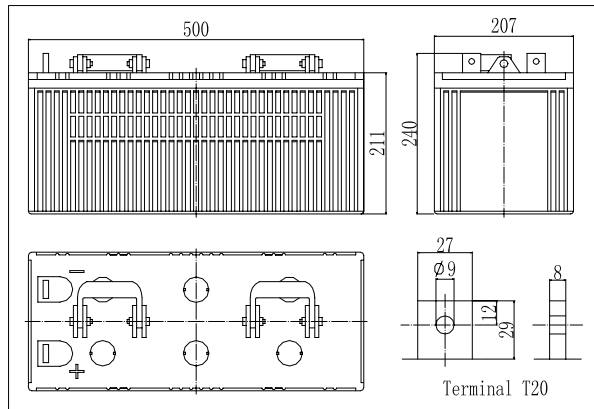

Specifications

Nominal Voltage	12 V	
Capacity(10HR, 25°C)	180 Ah	
Dimension	Length	500mm (19.69inch)
	Width	207mm (8.15inch)
	Height	211mm (8.31inch)
	Total Height	240mm (9.45inch)
Approx. Weight	58kg (127.9lbs)	
Internal resistance (Fully charged, 25°C)	Approx. 3.5m Ω	
Capacity affected by temperature (10HR)	40°C	102%
	25°C	100%
	0°C	85%
	-15°C	65%
Self-discharge (25°C)	3 month	Remaining Capacity: 91%
	6 month	Remaining Capacity: 82%
	12 month	Remaining Capacity: 65%
Nominal operating temperature	25°C ± 3°C (77°F ± 5°F)	
Operating temperature range	-15°C ~ 50°C (5°F ~ 122°F)	
Float charging voltage(25°C)	13.50 to 13.80V	
Cyclic charging voltage(25°C)	14.50 to 14.90V	
Maximum charging current	54A	
Terminal material	Lead	
Maximum discharge current	1400A(5 sec.)	

- ◆ Absorbent glass mat technology;
- ◆ Recognized by UL & CE;
- ◆ ABS container.

Charging Characteristics(25°C)

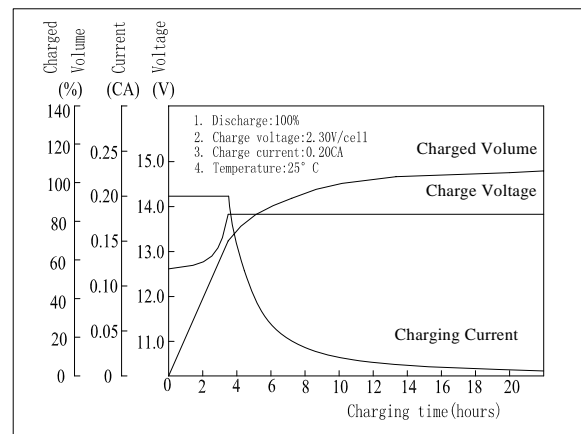

Cycle Life(25°C)

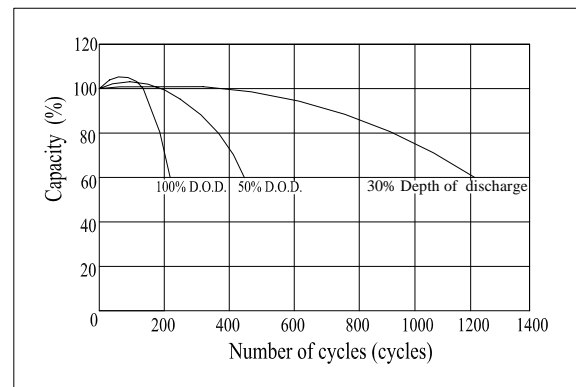

Note: Floating life at 20°C designed for 7 to 10 years.

Constant Current Discharge Characteristics (A, 25°C)

F.V/TIME	5min	10min	15min	30min	60min	3h	5h	10h	20h
9.60V	580	390	310	195	117	45.7	33.0	18.3	9.64
10.2V	551	371	298	187	112	45.0	32.5	18.1	9.56
10.8V	518	348	283	178	107	44.1	31.9	18.0	9.50

Constant Power Discharge Characteristics (Watt, 25°C)

F.V/TIME	5min	10min	15min	30min	60min	3h	5h	10h	20h
9.60V	6090	4212	3404	2188	1334	537	390	218	116
10.2V	5786	4001	3268	2100	1280	529	384	216	115
10.8V	5438	3761	3104	1995	1216	519	376	216	115