

**Dimensions**

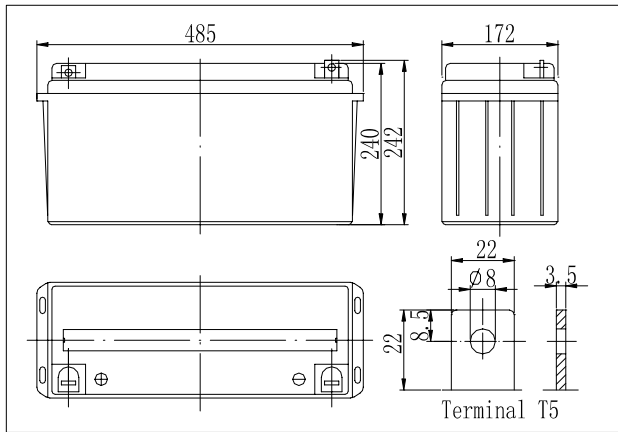

**Specifications**

Nominal Voltage	12 V	
Capacity(10HR, 25°C)	150 Ah	
Dimension	Length	485mm (19.09inch)
	Width	172mm (6.77inch)
	Height	240mm (9.45inch)
	Total Height	242mm (9.53inch)
Approx. Weight	47kg (103.6lbs)	
Internal resistance (Fully charged, 25°C)	Approx. 3.5m Ω	
Capacity affected by temperature (10HR)	40°C	102%
	25°C	100%
	0°C	85%
	-15°C	65%
Self-discharge (25°C)	3 month	Remaining Capacity: 91%
	6 month	Remaining Capacity: 82%
	12 month	Remaining Capacity: 65%
Nominal operating temperature	25°C ± 3°C (77°F ± 5°F)	
Operating temperature range	-15°C ~ 50°C (5°F ~ 122°F)	
Float charging voltage(25°C)	13.50 to 13.80V	
Cyclic charging voltage(25°C)	14.50 to 14.90V	
Maximum charging current	45A	
Terminal material	Copper	
Maximum discharge current	1200A(5 sec.)	

- ◆ Absorbent glass mat technology;
- ◆ Recognized by UL & CE;
- ◆ ABS container.

**Charging Characteristics(25°C)**

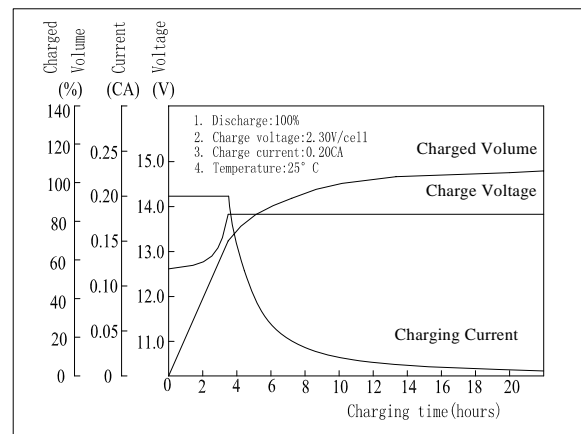

**Cycle Life(25°C)**

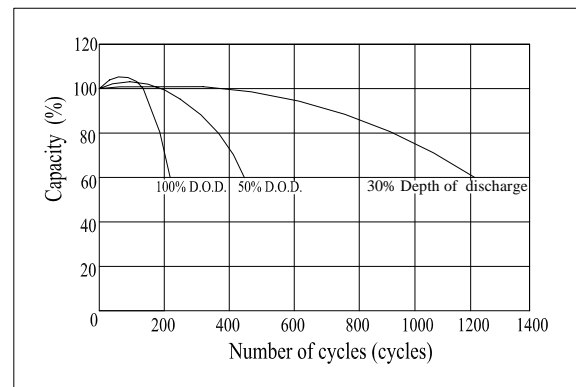

Note: Floating life at 20°C designed for 7 to 10 years.

**Constant Current Discharge Characteristics (A, 25°C)**

F.V/TIME	5min	10min	15min	30min	60min	3h	5h	10h	20h
9.60V	450	330	270	160	97.5	39.6	27.6	15.3	7.90
10.2V	428	314	259	154	93.6	39.0	27.2	15.2	7.90
10.8V	402	295	246	146	88.9	38.2	26.7	15.0	7.80

**Constant Power Discharge Characteristics (Watt, 25°C)**

F.V/TIME	5min	10min	15min	30min	60min	3h	5h	10h	20h
9.60V	4725	3564	2965	1795	1112	466	326	183	94.8
10.2V	4494	3391	2844	1728	1067	459	322	181	94.8
10.8V	4221	3186	2701	1638	1013	450	316	179	93.6