

Dimensions

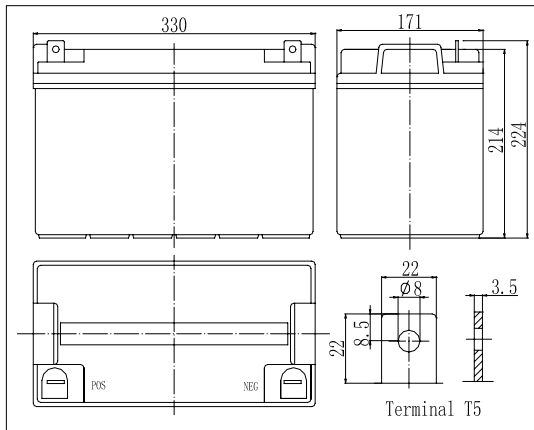

Specifications

Nominal Voltage	12 V	
Capacity(10HR, 25°C)	120 Ah	
Dimension	Length	330mm (12.99inch)
	Width	171mm (6.73inch)
	Height	214mm (8.43inch)
	Total Height	224mm (8.82inch)
Approx. Weight	32.5kg (71.7lbs)	
Internal resistance (Fully charged, 25°C)	Approx.4m Ω	
Capacity affected by temperature (10HR)	40°C	102%
	25°C	100%
	0°C	85%
	-15°C	65%
Self-discharge (25°C)	3 month	Remaining Capacity: 91%
	6 month	Remaining Capacity: 82%
	12 month	Remaining Capacity: 65%
Nominal operating temperature	25°C ± 3°C (77°F ± 5°F)	
Operating temperature range	-15°C ~ 50°C (5°F ~ 122°F)	
Float charging voltage(25°C)	13.50 to 13.80V	
Cyclic charging voltage(25°C)	14.50 to 14.90V	
Maximum charging current	36A	
Terminal material	Copper	
Maximum discharge current	960A(5 sec.)	

- ◆ Absorbent glass mat technology;
- ◆ Recognized by UL & CE;
- ◆ ABS container.

Charging Characteristics(25°C)

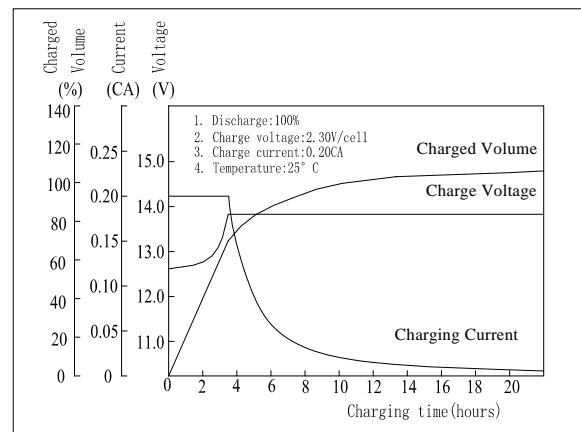

Cycle Life(25°C)

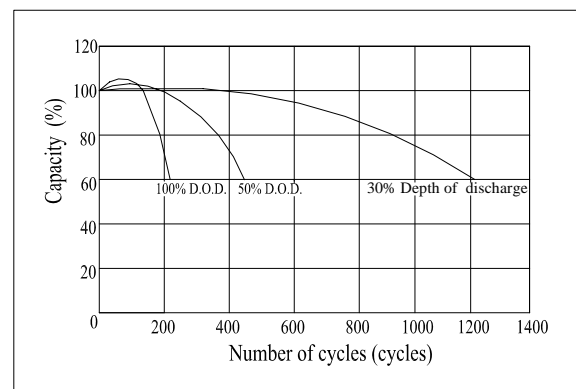

Note: Floating life at 20°C designed for 7 to 10 years.

Constant Current Discharge Characteristics (A, 25°C)

F.V/TIME	5min	10min	15min	30min	60min	3h	5h	10h	20h
9.60V	380	255	200	128	72.0	29.9	19.5	11.8	5.94
10.2V	361	242	192	123	69.1	29.5	19.2	11.7	5.89
10.8V	339	228	182	117	65.7	28.9	18.8	11.6	5.85

Constant Power Discharge Characteristics (Watt, 25°C)

F.V/TIME	5min	10min	15min	30min	60min	3h	5h	10h	20h
9.60V	3990	2754	2196	1436	821	352	230	141	71.3
10.2V	3791	2616	2108	1379	788	347	227	140	70.6
10.8V	3563	2459	2003	1310	749	340	222	139	70.2