

Dimensions

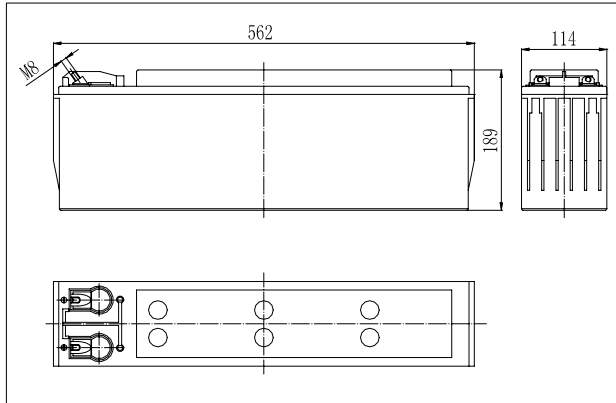

Specifications

Nominal Voltage	12 V	
Capacity(10HR, 25°C)	75Ah	
Dimension	Length	562mm (22.13inch)
	Width	114mm (4.49inch)
	Height	189mm (7.44inch)
	Total Height	189mm (7.44inch)
Approx. Weight	28.5kg (62.8lbs)	
Internal resistance (Fully charged, 25°C)	Approx. 5.5mΩ	
Capacity affected by temperature (10HR)	40°C	102%
	25°C	100%
	0°C	85%
	-15°C	65%
Self-discharge (25°C)	3 month	Remaining Capacity: 91%
	6 month	Remaining Capacity: 82%
	12 month	Remaining Capacity: 65%
Nominal operating temperature	25°C ± 3°C (77°F ± 5°F)	
Operating temperature range	-15°C ~ 50°C (5°F ~ 122°F)	
Float charging voltage(25°C)	13.50 to 13.80V	
Cyclic charging voltage(25°C)	14.50 to 14.90V	
Maximum charging current	22.5A	
Terminal type	M8 threaded post	
Maximum discharge current	750A(5 sec.)	

- ◆ Absorbent glass mat technology;
- ◆ Recognized by UL & CE;
- ◆ ABS container.

Constant Current Discharge Characteristics (A, 25°C)

F.V/TIME	5min	10min	15min	30min	60min	3h	5h	10h	20h
9.60V	275	182	142	81.0	49.5	20.3	13.4	7.65	3.97
10.2V	261	171	136	77.8	47.5	20.0	13.2	7.60	3.97
10.8V	246	161	130	73.9	45.1	19.6	12.9	7.50	3.94

Constant Power Discharge Characteristics (Watt, 25°C)

F.V/TIME	5min	10min	15min	30min	60min	3h	5h	10h	20h
9.60V	2888	1945	1559	909	564	239	158	91.3	47.6
10.2V	2743	1847	1497	872	542	235	156	90.7	47.6
10.8V	2579	1736	1422	829	515	230	152	89.6	47.3

Charging Characteristics(25°C)

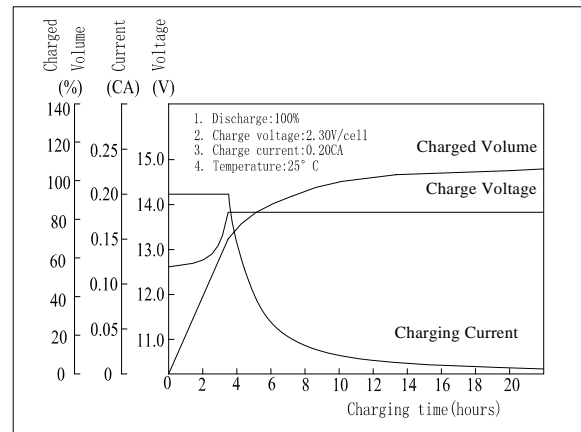

Floating Life Characteristics (25°C)

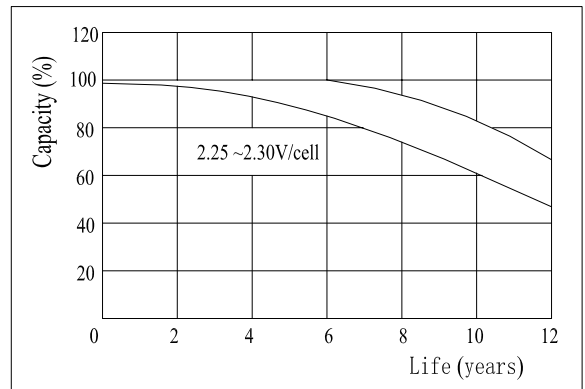

Note: Floating life at 20°C designed for more than 12 years.