

Dimensions

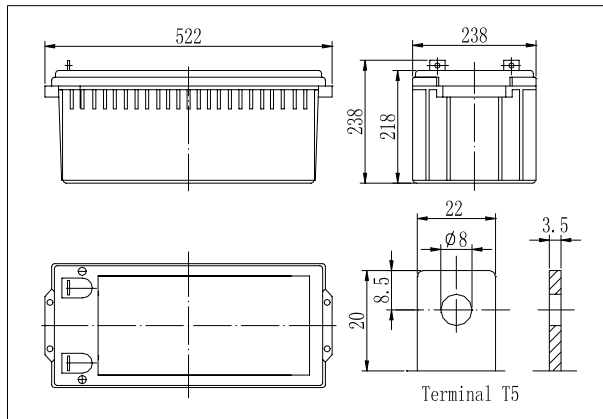

Specifications

Nominal Voltage	12 V	
Capacity(10HR, 25°C)	200 Ah	
Dimension	Length	522mm (20.55inch)
	Width	238mm (9.37inch)
	Height	218mm (8.58inch)
	Total Height	221mm (8.70inch)
Approx. Weight	65kg (143lbs)	
Internal resistance (Fully charged, 25°C)	Approx. 3.5mΩ	
Capacity affected by temperature (10HR)	40°C	102%
	25°C	100%
	0°C	85%
	-15°C	65%
Self-discharge (25°C)	3 month	Remaining Capacity: 91%
	6 month	Remaining Capacity: 82%
	12 month	Remaining Capacity: 65%
Nominal operating temperature	25°C ± 3°C (77°F ± 5°F)	
Operating temperature range	-15°C ~ 50°C (5°F ~ 122°F)	
Float charging voltage(25°C)	13.50 to 13.80V	
Cyclic charging voltage(25°C)	14.50 to 14.90V	
Maximum charging current	60A	
Terminal material	Copper	
Maximum discharge current	1500A(5 sec.)	

- ◆ Absorbent glass mat technology;
- ◆ Recognized by UL & CE;
- ◆ ABS container.

Charging Characteristics(25°C)

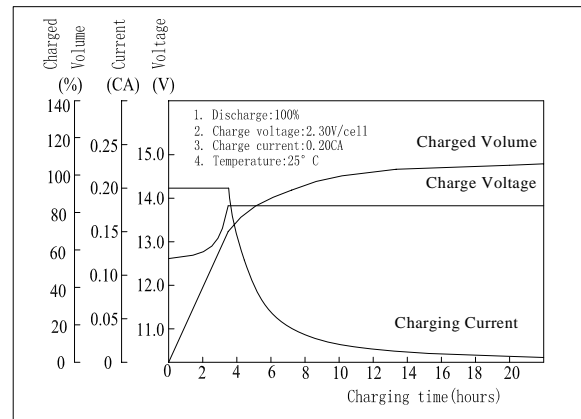

Floating Life Characteristics (25°C)

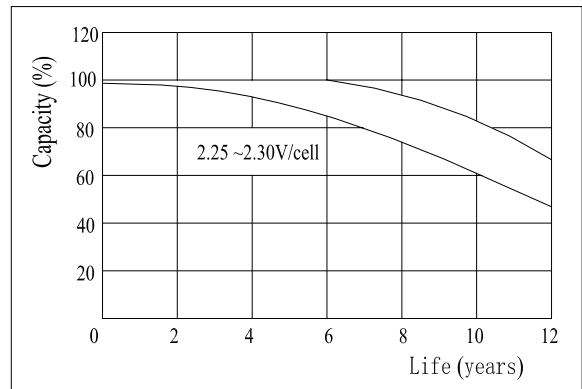

Note: Floating life at 20°C designed for more than 12 years.

Constant Current Discharge Characteristics (A, 25°C)

F.V/TIME	5min	10min	15min	30min	60min	3h	5h	10h	20h
9.60V	631	417	363	206	130	55.0	38.2	20.3	10.4
10.2V	599	396	348	198	125	53.5	37.0	20.1	10.3
10.8V	563	372	331	188	119	52.4	36.3	20.0	10.2

Constant Power Discharge Characteristics (Watt, 25°C)

F.V/TIME	5min	10min	15min	30min	60min	3h	5h	10h	20h
9.60V	6620	4505	3981	2309	1482	639	444	242	124
10.2V	6289	4279	3822	2217	1423	629	437	240	123
10.8V	5912	4023	3631	2106	1352	617	429	240	122