

Dimensions

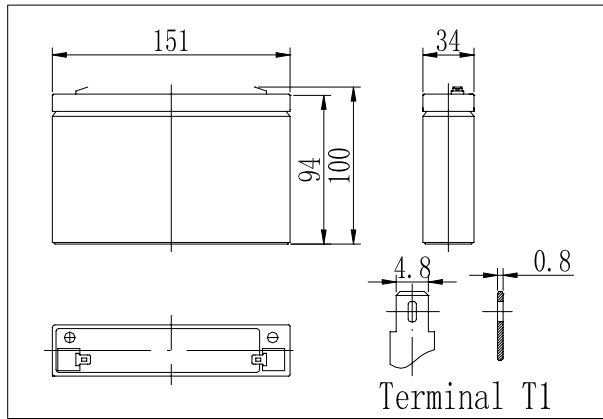

Specifications

Nominal Voltage		6 V
Capacity(20HR, 25°C)		7 Ah
Dimension	Length	151mm (5.94inch)
	Width	34mm (1.34inch)
	Height	94mm (3.70inch)
	Total Height	100mm (3.94inch)
Approx. Weight		1.20kg (2.65lbs)
Internal resistance (Fully charged, 25°C)		Approx. 15mΩ
Capacity affected by temperature (20HR)	40°C	102%
	25°C	100%
	0°C	85%
	-15°C	65%
Self-discharge (25°C)	3 month	Remaining Capacity: 91%
	6 month	Remaining Capacity: 82%
	12 month	Remaining Capacity: 65%
Nominal operating temperature		25°C ± 3°C (77°F ± 5°F)
Operating temperature range		-15°C ~ 50°C (5°F ~ 122°F)
Float charging voltage(25°C)		6.80 to 6.90V
Cyclic charging voltage(25°C)		7.25 to 7.45V
Maximum charging current		2.1A
Terminal material		Copper
Maximum discharge current		105A(5 sec.)

- ◆ Absorbent glass mat technology;
- ◆ Recognized by UL & CE;
- ◆ ABS container.

Charging Characteristics(25°C)

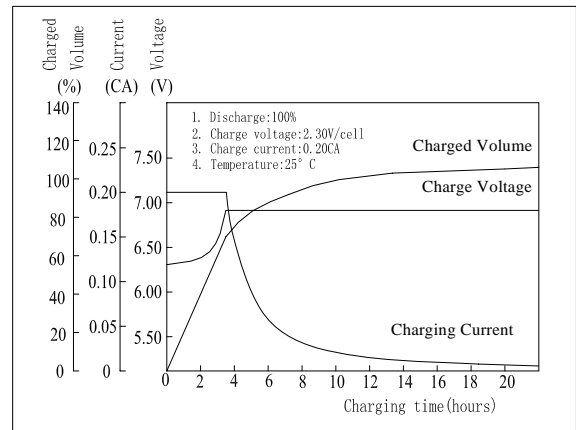

Cycle Life(25°C)

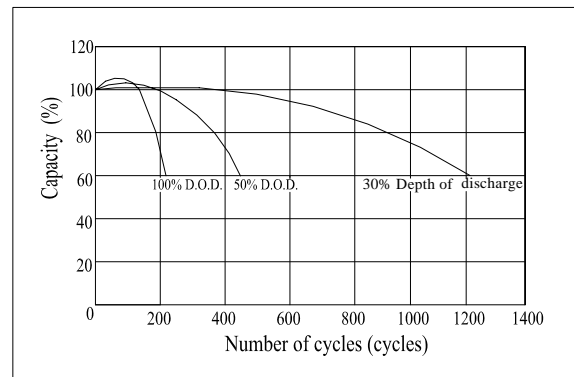

Note: Floating life at 20°C designed for 3 to 5 years.

Constant Current Discharge Characteristics (A, 25°C)

F.V/TIME	5min	10min	15min	30min	60min	3h	5h	10h	20h
4.80V	27.0	18.0	14.0	8.40	4.70	1.73	1.15	0.71	0.37
5.10V	25.7	17.1	13.4	8.06	4.55	1.70	1.13	0.70	0.36
5.40V	24.2	16.1	12.7	7.66	4.35	1.65	1.10	0.68	0.35

Constant Power Discharge Characteristics (Watt, 25°C)

F.V/TIME	5min	10min	15min	30min	60min	3h	5h	10h	20h
4.80V	151	102	80.0	47.1	27.2	10.3	6.87	4.26	2.20
5.10V	144	95.5	76.5	45.2	26.4	10.1	6.75	4.20	2.16
5.40V	135	90.0	72.5	43.0	25.2	9.8	6.57	4.08	2.10

