

**Dimensions**

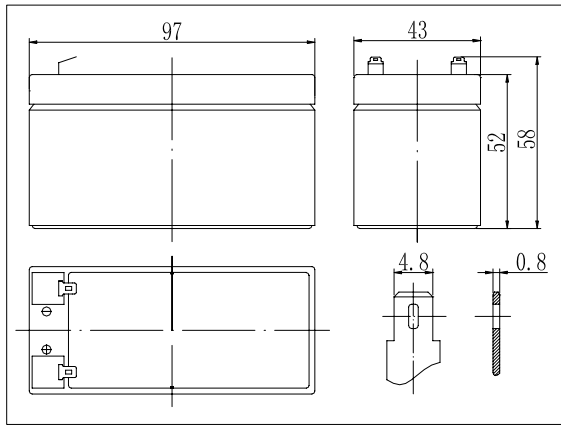

**Specifications**

Nominal Voltage	12 V	
Capacity(20HR, 25°C)	1.2 Ah	
Dimension	Length	97mm (3.82inch)
	Width	43mm (1.69inch)
	Height	52mm (2.05inch)
	Total Height	58mm (2.28inch)
Approx. Weight	0.61kg (1.35lbs)	
Internal resistance (Fully charged, 25°C)	Approx. 95mΩ	
Capacity affected by temperature (20HR)	40°C	102%
	25°C	100%
	0°C	85%
	-15°C	65%
Self-discharge (25°C)	3 month	Remaining Capacity: 91%
	6 month	Remaining Capacity: 82%
	12 month	Remaining Capacity: 65%
Nominal operating temperature	25°C ± 3°C (77°F ± 5°F)	
Operating temperature range	-15°C ~ 50°C (5°F ~ 122°F)	
Float charging voltage(25°C)	13.60 to 13.80V	
Cyclic charging voltage(25°C)	14.50 to 14.90V	
Maximum charging current	0.36A	
Terminal material	Copper	
Maximum discharge current	18A(5 sec.)	

- ◆ Absorbent glass mat technology;
- ◆ Recognized by UL & CE;
- ◆ ABS container.

**Constant Current Discharge Characteristics (A, 25°C)**

F.V/TIME	5min	10min	15min	30min	60min	3h	5h	10h	20h
9.60V	5.00	3.20	2.50	1.45	0.82	0.33	0.22	0.12	0.06
10.2V	4.75	3.04	2.40	1.39	0.79	0.33	0.22	0.12	0.06
10.8V	4.47	2.86	2.28	1.32	0.75	0.32	0.21	0.12	0.06

**Constant Power Discharge Characteristics (Watt, 25°C)**

F.V/TIME	5min	10min	15min	30min	60min	3h	5h	10h	20h
9.60V	55.8	36.1	28.5	16.6	9.50	3.92	2.63	1.44	0.72
10.2V	53.0	34.3	27.4	15.9	9.15	3.92	2.63	1.44	0.72
10.8V	49.9	32.3	26.0	15.1	8.69	3.80	2.51	1.44	0.72

**Charging Characteristics(25°C)**

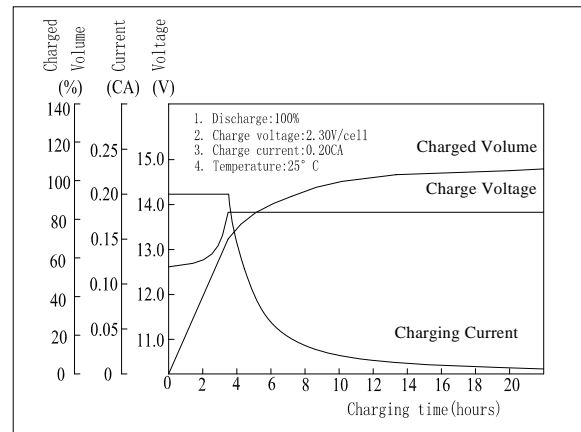

**Cycle Life(25°C)**

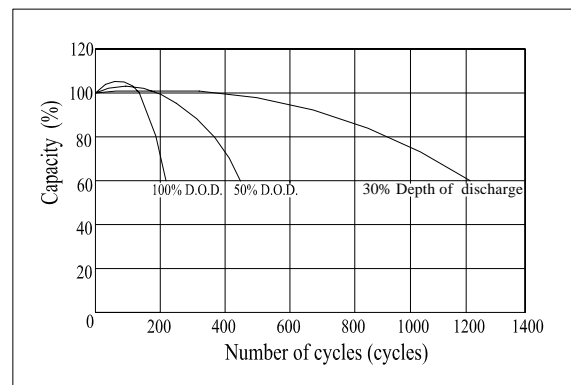

Note: Floating life at 20°C designed for 3 to 5 years.