

**Dimensions**

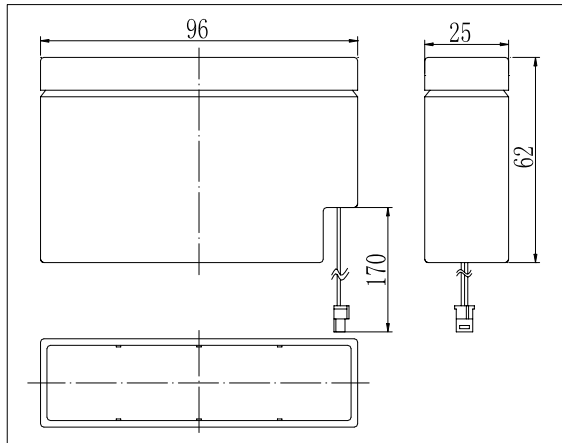

**Specifications**

Nominal Voltage	12 V	
Capacity(20HR, 25°C)	0.8 Ah	
Dimension	Length	96mm (3.78inch)
	Width	25mm (0.98inch)
	Height	62mm (2.44inch)
	Total Height	62mm (2.44inch)
Approx. Weight	0.34kg (0.75lbs)	
Internal resistance (Fully charged, 25°C)	Approx. 260mΩ	
Capacity affected by temperature (20HR)	40°C	102%
	25°C	100%
	0°C	85%
	-15°C	65%
Self-discharge (25°C)	3 month	Remaining Capacity: 91%
	6 month	Remaining Capacity: 82%
	12 month	Remaining Capacity: 65%
Nominal operating temperature	25°C ± 3°C (77°F ± 5°F)	
Operating temperature range	-15°C ~ 50°C (5°F ~ 122°F)	
Float charging voltage(25°C)	13.60 to 13.80V	
Cyclic charging voltage(25°C)	14.50 to 14.90V	
Maximum charging current	0.24A	
Terminal material	Plug	
Maximum discharge current	12A(5 sec.)	

- ◆ Absorbent glass mat technology;
- ◆ Recognized by UL & CE;
- ◆ ABS container.

**Constant Current Discharge Characteristics (A, 25°C)**

F.V/TIME	5min	10min	15min	30min	60min	3h	5h	10h	20h
9.60V	2.60	1.60	1.26	0.73	0.46	0.18	0.12	0.07	0.04
10.2V	2.47	1.52	1.21	0.70	0.44	0.18	0.12	0.07	0.04
10.8V	2.32	1.43	1.15	0.67	0.42	0.18	0.12	0.07	0.04

**Constant Power Discharge Characteristics (Watt, 25°C)**

F.V/TIME	5min	10min	15min	30min	60min	3h	5h	10h	20h
9.60V	29.0	18.0	14.4	8.37	5.33	2.17	1.45	0.85	0.49
10.2V	27.6	17.1	13.8	8.03	5.11	2.14	1.43	0.85	0.48
10.8V	25.9	16.1	13.1	7.63	4.86	2.10	1.40	0.85	0.48

**Charging Characteristics(25°C)**

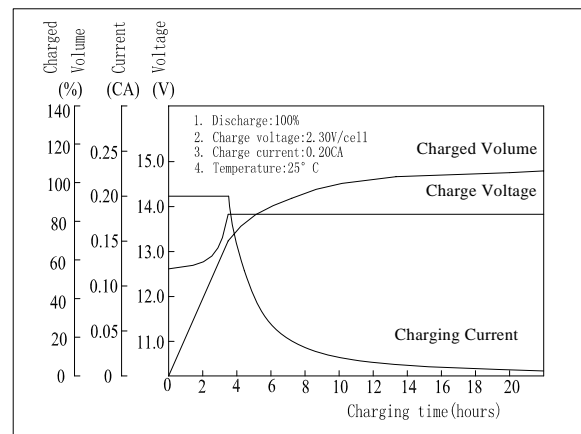

**Cycle Life(25°C)**

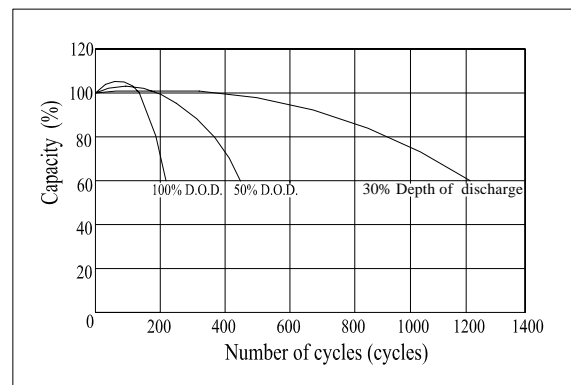

Note: Floating life at 20°C designed for 3 to 5 years.